

OPERATOR'S MANUAL

91ST (Helicopter Engine)

Fig.1

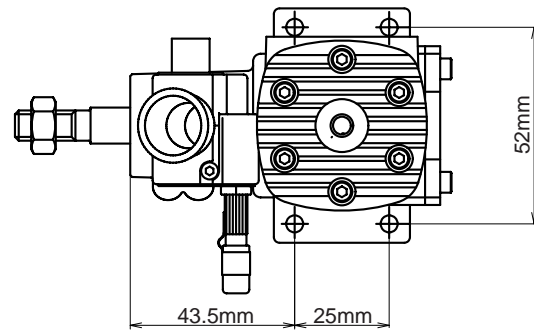

SPECIFICATIONS

Bore	27.7mm
Stroke	24.8mm
Displacement	14.95cc
Weight	540g
Practical rpm	2,000 ~17,000

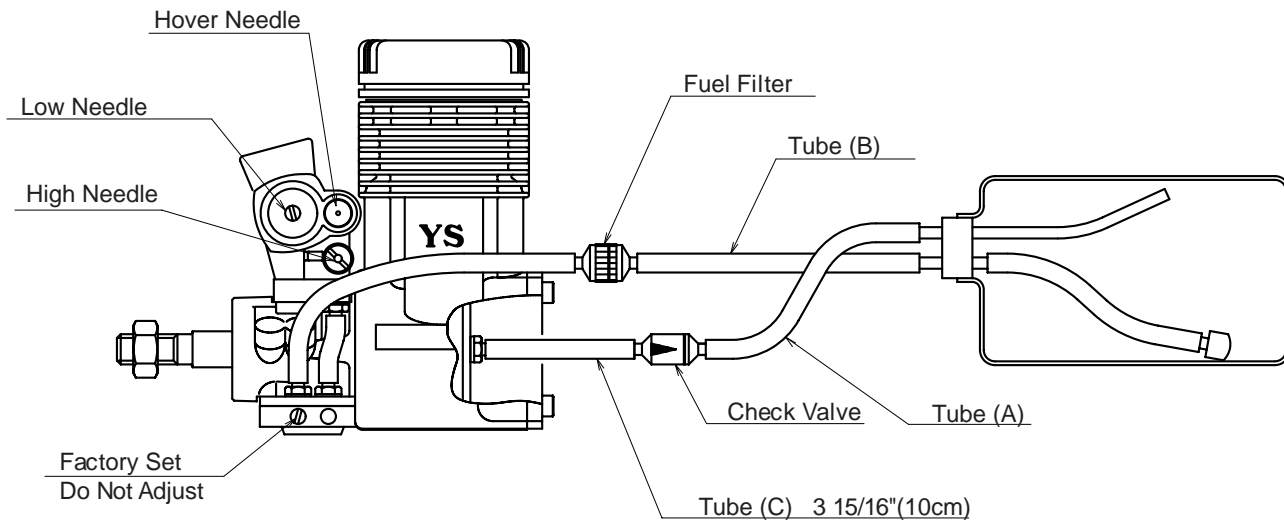

FEATURES

The 91ST is the latest in helicopter engine technology from YS. It is a bored and stroked version of our popular YS61ST-2 which has been optimized to provide the ultimate in reliable horsepower for your helicopter.

- New large bore cylinder design for superior operation.
- New carburetor design for easier adjustments.
- Factory preset fuel regulator.
- Same physical size as 61ST-2, 80ST making it easy to add more power to your helicopter.

CAUTION

Using gear ratios higher than 9.0 to 1 may result in engine damage from overspeed.

GEAR RATIO

You should be using an engine to main rotor gear ratio of 1-7.5 to 1-8.0. Please check with your helicopter manufacturer to obtain the correct gear ratio.

INSTALLATION

- The fuel lines should be connected to the fuel tank as shown in the above figure. Be careful to install the check valve in the correct direction. Since the tank is exposed to high pressures, be sure that all connections are tight to prevent pressures leakage.

- Since the engine is sensitive to dirt in the fuel, a fuel filter must be used. (We recommend the 6720 fuel filter.)
- Tube(C) should be set exactly at 3 15/16" or (10cm) between the engine and check valve. DO NOT use any other type of check valve. The check valve is designed exclusively for the 91ST.
- Adjust your throttle linkage and curve using the alignment indentations on the carburetor body located on the throttle arm side of the carb body. PLEASE NOTE that the hover position is at 40% see FIG 2.

START UP

- Always remove Tube(A) at the check valve first before fueling. The fuel tank is pressurized and you need to relieve the pressure first. Disconnect Tube-b at the filter and fill the tank. Reconnect Tube(A) and (B).
- From the fully closed (clockwise) position, turn the needle valves counter clockwise as follows.

STARTING SETTINGS / OPERATING SETTINGS

Hover	1.75 open	1.75 ~1.50
Low	1.25 open	0.75 ~0.50
Full	1.25 open	1.25 ~0.75

- Close the throttle to the idle position and connect the glow plug driver. The engine is now ready for starting.

BREAK-IN

It is not necessary to mount this engine on a set stand for break-in. However, the engine should be adjusted slightly on the rich setting for the first few flights to insure proper break-in. Always use a good quality fuel which contain 15 ~30% nitromethane and an oil content of 20 ~23% low viscosity oil.

NEEDLE VALVE ADJUSTMENT

Idle, Hover and High needle valves all work the same way. Turning the needles clockwise will lean the fuel mixtures and counter clockwise will richen the fuel mixtures.

- Set needles as described in START-UP.
- Start the engine and check idle. Adjust as needed.
- Lift helicopter into a hover and check for the correct rotor RPM recommended by the kit manufacture. Once this is done take note of the amount of smoke being produced by the muffler. The mixture is correct for hover when there is a steady stream of smoke being produced.
- Land the helicopter for approximately 20~30 seconds. Lift the helicopter into a hover again taking note of the transition from idle to hover. If the engine exhibits a large amount of smoke and the throttle response is sluggish, you will need to adjust the idle and or the hover needle leaner to achieved a smooth transition. If the engine detonates and the smoke is inconsistent or a small amount is produced, the mixture is to lean.
- The high speed needle refines the fuel mixture for forward flights without affecting the hovering adjustment.

After the engine is started and warmed up, lift off into a hover and check that the engine is running smooth with a good trail of smoke. If everything is fine, open the throttle and enter forward flight. Take note of the amount of smoke like we did in a hover adjustment. It is correct when you see a noticeable steady smoke trail. Adjust the high-speed needle valve to obtain slightly rich but consistent setting.

STOPPING THE ENGINE

- Fully close the throttle barrel to stop the engine.
- As soon as the engine stops running, be sure that a fuel line clamp is used in Tube-B to prevent fuel from flowing into the engine.
- On the final flight of the day, the fuel line clamp should be used to stop the engine in order to prevent rust and corrosion.

FUEL AND GLOW PLUG

We have found that the fuel and glow plugs listed below will give the best engine performance.

Fuel
Powermaster 30% Special Heli Blend
Cool Power 30% Special Heli Blend

Glow Plug _ YS #2 Enya #3 OS #8

IMPORTANT!

Silicone rubber is used in many parts of the YS engine. Use only glow fuel of methanol for cleaning. Gasoline and other volatile solutions will damage silicone if used.

Fig.2

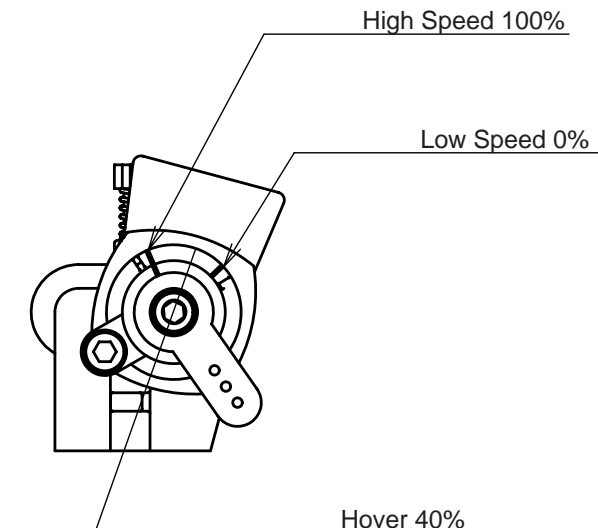

91ST Parts List

#	PART#	DESCRIPTION	QTY
1	S5101	Crankcase	1
2	S5102	Cylinder Head	1
3	S5103	Head Gasket	1
4	S5104	Head Screws	6
5	S5105	Cylinder Liner	1
6	S5106	Piston	1
7	S5107	Piston Ring	1
8	S7108	Wrist Pin	1
9	R6108	Wrist Pin Retainer	2
10	S5110	Con Rod	1
11	S5111	Crankshaft	1
12	R6211	Front Bearing	1
13	S7113	Rear Bearing	1
14	R6115	Drive Washer Spacer	1
15	R6217	Propeller Nut	1
16	S5116	Back Plate	1
17	S5117	Back Plate Gasket	1
18	R6120	Back Plate Screw	4
19	S5119	Carburetor Body	1
20	S5120	Carburetor Gasket	1
21	S5121	Throttle Barrel	1
22	S5122	Seal Ring	1
23	R6124	Throttle Barrel Retainer	1
24	S4125	Hover Needle Valve	1
25	F1546	Hover Needle O Ring	1
26	F1555	Hover Needle Seat	1
27	F1556	Hover Needle Seat O Ring	2
28	S5128	Needle Detent	2
29	S8130	High Speed Needle	1
30	R6230	High Speed Needle O Ring	1
31	S5131	Low Speed Needle	1
32	R6203	Low Speed Needle O Ring	1
33	F1260S	Throttle Arm	1
34	S7132	Carburetor Screws	2
35	S5135	Carburetor Subplate	1
36	S7134	Regulator Subplate	1
37	S8138A	Regulator Assy.	1
38	S7136	Diaphragm	1
39	S7140	Regulator gasket	1
40	S7139	Regulator Screws	2
41	S7143	Nipple	1
42	S7144	Check Valve	1
	S5143	Gasket Set	3
	S8146	O ring set	5
	S5105S	Piston / Ring / Liner Set	1
	S5119S	Carburetor Assy.	1
	S4125S	Needle Valve Assy.	1

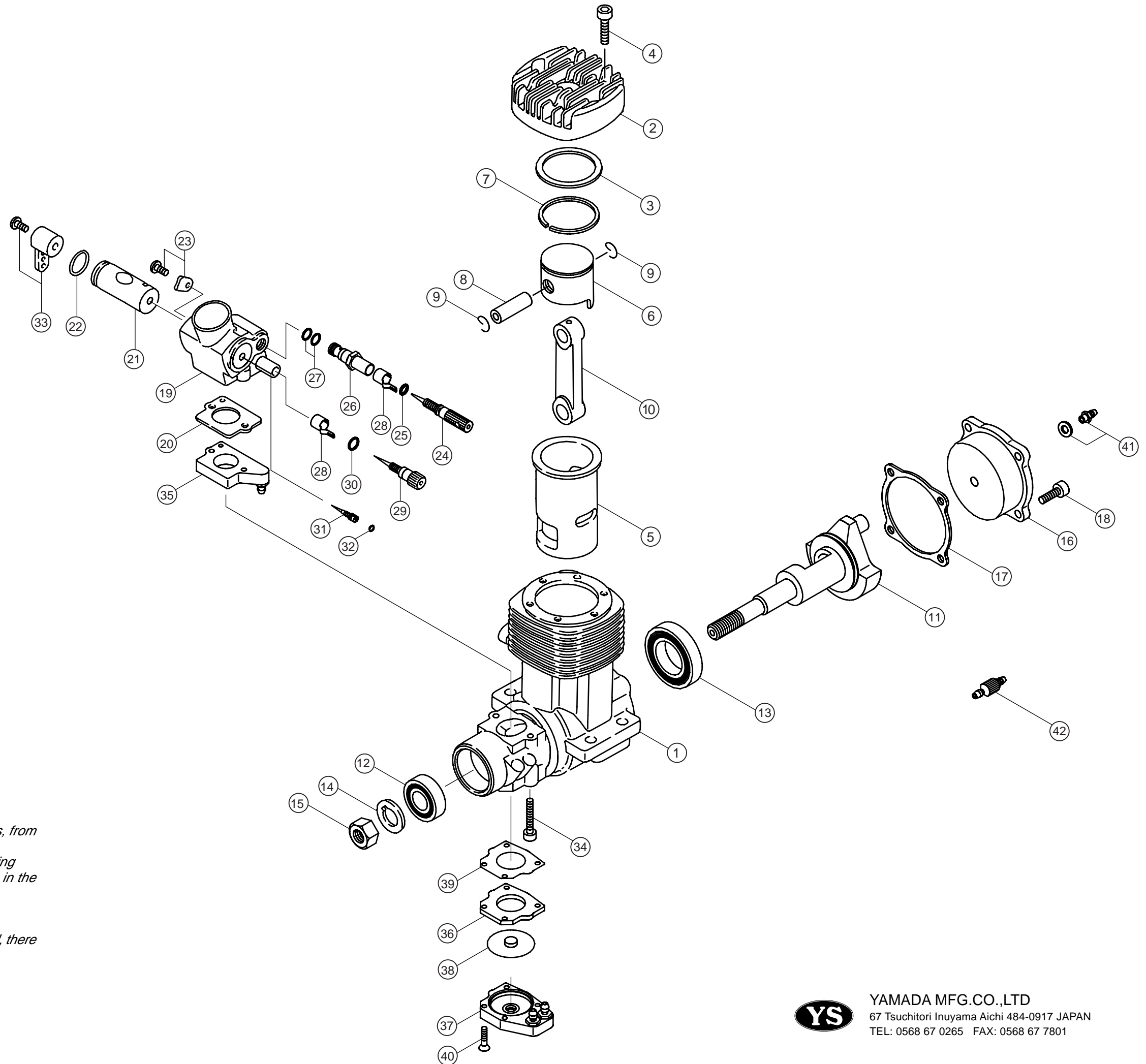

WARRANTY

Strict quality control is implemented by our factory in all phases, from parts manufacturing to final assembly.

If performance deteriorates or a part fails due to a manufacturing error, YS engine will repair or replace the engine at no charge in the period of one year from date of purchase.

Warranty does not cover normal maintenance.

Should the engine be modified, incorrectly assembled or abused, there will be a normal charge for parts and labor.



YAMADA MFG.CO.,LTD
67 Tsuchitori Inuyama Aichi 484-0917 JAPAN
TEL: 0568 67 0265 FAX: 0568 67 7801